

SURVEY PLAT FOR: DAVE KARLSTADT

BEING PART OF THE E 1/2
OF SECTION 25,
CENTER TOWNSHIP, T6N - R2E,
WILLIAMS COUNTY, OHIO

BOCKRATH & ASSOCIATES
ENGINEERING and SURVEYING, LLC
115 S. FAIR AVENUE, SUITE A - OTTAWA, OH 43875
PHONE: 419-523-5789 - FAX: 419-523-5799

1
2

~COUNTY ROAD B-75~

S 87°33'47" E 240.99'

N 71°33'00" E 394.61'

N 71°33'00" E 355.40'

S 71°33'00" W 319.99'

NORMAN R &
SARA R CHAMBERLAIN
OR VOL 339 - PG 2773
2.800 ACRES
PN. 062-250-01-011.001
SR VOL 27R - PG 347

BRADLEY & KRISTI DEWULF
OR VOL 340 - PG 990
8.060 ACRES
PN. 062-250-01-011.002
SR VOL 27R - PG 348

N 87°50'22" W 65.24'
N 75°48'49" E 92.47'

S 36°43'21" E 280.36'

N 61°33'44" E 235.09'

N 79°03'29" E 119.38'

N 58°41'10" E 176.44'

N 00°55'35" E 423.82'

5.636 ACRES

PT. PN. 062-250-01-011.000
(NOTE: TO BE TRANSFERRED TO OWNER
OF PN. 062-250-01-011.003)

S 82°00'41" W 534.42'

S 78°49'09" E 359.06'



JEREMY D HERMAN
OR VOL 342 - PG 707
13.640 ACRES
PN. 062-250-01-011.003
SR VOL 27R - PG 349

FITZENRIDER BROTHERS II LLC
OR VOL 347 - PG 3469
80.87 ACRES
PN. 062-250-01-012.000

I DO HEREBY CERTIFY THAT I HAVE SURVEYED SAID PARCEL
OF LAND AND THAT SAID PLAT OF SURVEY IS CORRECT TO
THE BEST OF MY KNOWLEDGE AND BELIEF. DIMENSIONS ARE
SHOWN IN FEET AND DECIMAL PARTS THEREOF. THIS PLAT
OF SURVEY IS RECORDED IN VOLUME 28R, PAGE 333 OF
THE WILLIAMS COUNTY RECORD OF SURVEYS.

3-27-23
Date

Seth D. Schroeder
Seth D. Schroeder, P.S.
Registered Surveyor No. 8784.
115 S. Fair Avenue, Suite A
Ottawa, Ohio 45875
419-523-5789

JOHN B & LISA M HESLOP
OR VOL 240 - PG 1444
0.92 ACRES
PN. 062-250-01-010.000

SE CORNER,
SE 1/4,
SECTION 25

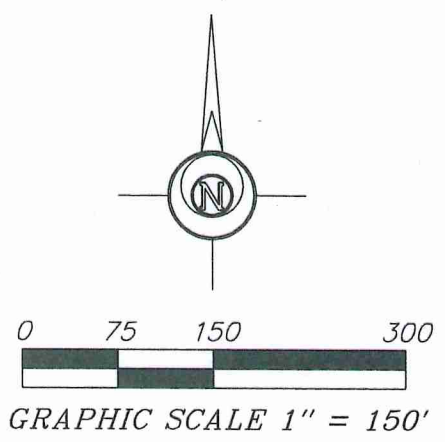

LEGEND

- 5/8" REBAR WITH ID CAP SET
- 5/8" REBAR WITH ID CAP FOUND
- 5/8" REBAR FOUND
- ⊗ RAILROAD SPIKE FOUND
- ⊠ MAGS MAG NAIL SET
- ⊠ MAGS MAG NAIL FOUND
- POB POINT OF BEGINNING
- POC POINT OF COMMENCEMENT
- M MEASURED
- R RECORDED

NOTE: SURVEY BEARINGS BASED ON OHIO NORTH
ZONE STATE PLANE COORDINATES OBTAINED FROM
THE OHIO DOT VRS NETWORK

KARLSTADT FARMS LLC
OR VOL 340 - PG 1168
30.730 ACRES
PN. 062-250-01-011.000
SR VOL 27R - PG 350

~MEANDERINGS OF LICK CREEK~

EAST LINE, SE 1/4, SEC. 25
S 01°03'35" W 1805.18'

~COUNTY ROAD 13~

SURVEY PLAT FOR: DAVE KARLSTADT

BEING PART OF THE E 1/2
OF SECTION 25,
CENTER TOWNSHIP, T6N - R2E,
WILLIAMS COUNTY, OHIO

BOCKRATH & ASSOCIATES

ENGINEERING and SURVEYING, LLC
115 S. FAIR AVENUE, SUITE A - OTTAWA, OH 45875
PHONE: 419-523-5789 - FAX: 419-523-5799

2

2

5.636 ACRES

Situated as being part of the East Half of Section 25, Township 6 North, Range 2 East, Center Township, Williams County, Ohio, also being part of a 30.730 acre tract of land as recorded in Official Record Volume 340, Page 1168 of the Williams County Deed Records and Survey Record Volume 27R, Page 350 and more particularly described as follows:

Commencing at a mag nail found marking the Southeast corner of the Southeast Quarter of Section 25;

Thence North 01°03'35" East along the East line of said East Half of Section 25 (County Road 13) a distance of 2,307.49 feet to a mag nail found marking the Southeast corner of said 30.730 acre tract and the Northeast corner of a 0.92 acre tract of land as recorded in Official Record Volume 240, Page 1444 and the POINT OF BEGINNING;

Thence along the perimeter of said 30.730 acre tract the following five (5) courses:

North 88°56'25" West a distance of 300.00 feet to a 5/8 inch rebar with ID cap found marking the Northwest corner of said 0.92 acre tract, passing a 5/8 inch rebar with ID cap found at 45.03 feet;

North 13°39'47" West a distance of 502.88 feet to a 5/8 inch rebar with ID cap found;

North 48°09'44" West a distance of 249.15 feet to a 5/8 inch rebar with ID cap found;

South 82°00'41" West a distance of 534.42 feet to a point, passing a 5/8 inch rebar with ID cap found at 519.42 feet;

North 00°55'35" East a distance of 423.82 feet to a point marking the Southwestern corner of a 8.060 acre tract of land as recorded in Survey Record Volume 27R, Page 348;

Thence North 61°33'44" East along the Southern line of said 8.060 acre tract a distance of 27.00 feet to a 5/8 inch rebar with ID cap found;

Thence along a new division the following four (4) courses:

South 53°59'41" East a distance of 616.39 feet to a 5/8 inch rebar with ID cap found;

South 78°49'09" East a distance of 359.06 feet to a 5/8 inch rebar with ID cap set;

South 01°03'35" West a distance of 411.00 feet to a 5/8 inch rebar with ID cap set;

South 88°56'25" East a distance of 263.00 feet to a mag nail set on said East line of said East Half (County Road 13) and the East line of said 30.730 acre tract, passing a 5/8 inch rebar with ID cap set at 243.00 feet;

Thence South 01°03'35" West along said East line (County Road 13) a distance of 175.00 feet to the POINT OF BEGINNING, said tract containing 5.636 acres of land, more or less.

Subject to all legal highways, easements, and restrictions of use whether apparent and/or of record and is from an actual survey performed in March, 2023, under the supervision of Ohio Professional Surveyor Seth D. Schroeder, Ohio Surveyor No. 8784.

Note: The bearings used in this description are on an assumed meridian assuming the East line of Section 25 to be North 01°03'35" East and are for the purpose of angle determination only.